

CARLOW CONCRETE TANKS

DRAWING TITLE:
1.9m Ø x 4m PRECAST CONCRETE
PUMP CHAMBER WITH 1m RISER
- TYPICAL DETAILS.

Drawn By: T. Armstrong

Date: 17/04/09

Revision: B

TYPICAL INSITU BALLAST CONCRETE SPECIFICATION:
CONCRETE GRADE: C28/35
MIN. CEMENT CONTENT: 320 kg/m³
MAX. W/C RATIO: 0.55
MAX. AGGREGATE SIZE: 20mm
STEEL FIBRE DOSAGE: 20 kg/m³
STEEL FIBRE TYPE: DRAMIX RL 45/50 BN
(OR SIMILAR)

STANDARD UNIT WEIGHTS:
- STANDARD BASE UNIT: 6.1 TONNES
- 1m RISER: 1.6 TONNES
- 2m RISER: 2.4 TONNES
- 3m RISER: 4.0 TONNES
- LID UNIT: 1.5 TONNES

STANDARD LID DESIGN LOADS:

IMPOSED LOAD: 10 kN/m² UDL OR 5,850 kg WHEEL LOAD
DEAD LOAD: UP TO 1m OVERBURDEN
HEAVY DUTY OR CUSTOM LIDS CAN BE MANUFACTURED FOR MORE ONEROUS APPLICATIONS.

STANDARD ACCESS OPENING SIZES:

- 1400mm x 850mm
- 900mm x 600mm
- 600mm x 600mm

NON STANDARD SIZES ARE AVAILABLE ON REQUEST

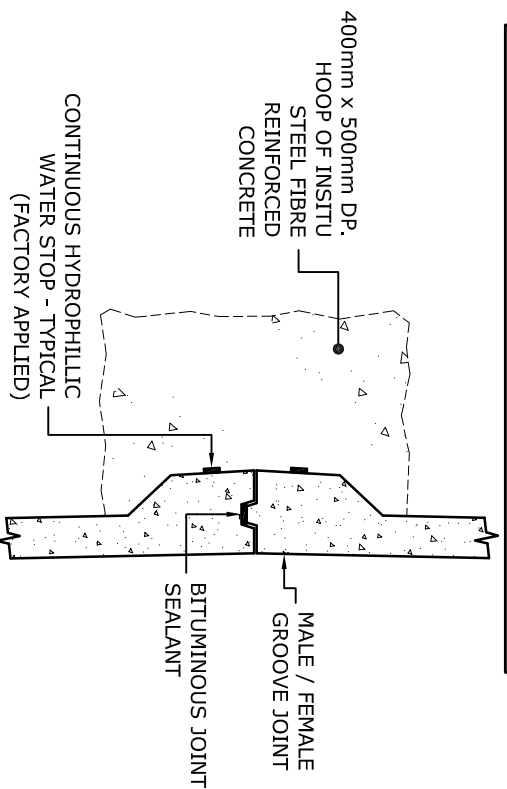

PRECAST JOINT DETAIL:
SCALE: 1:15

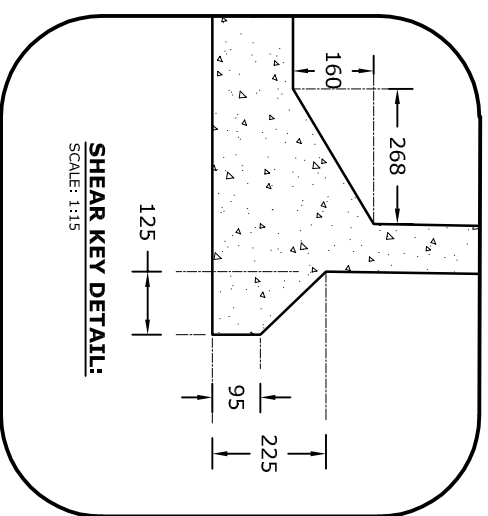

SHEAR KEY DETAIL:
SCALE: 1:15

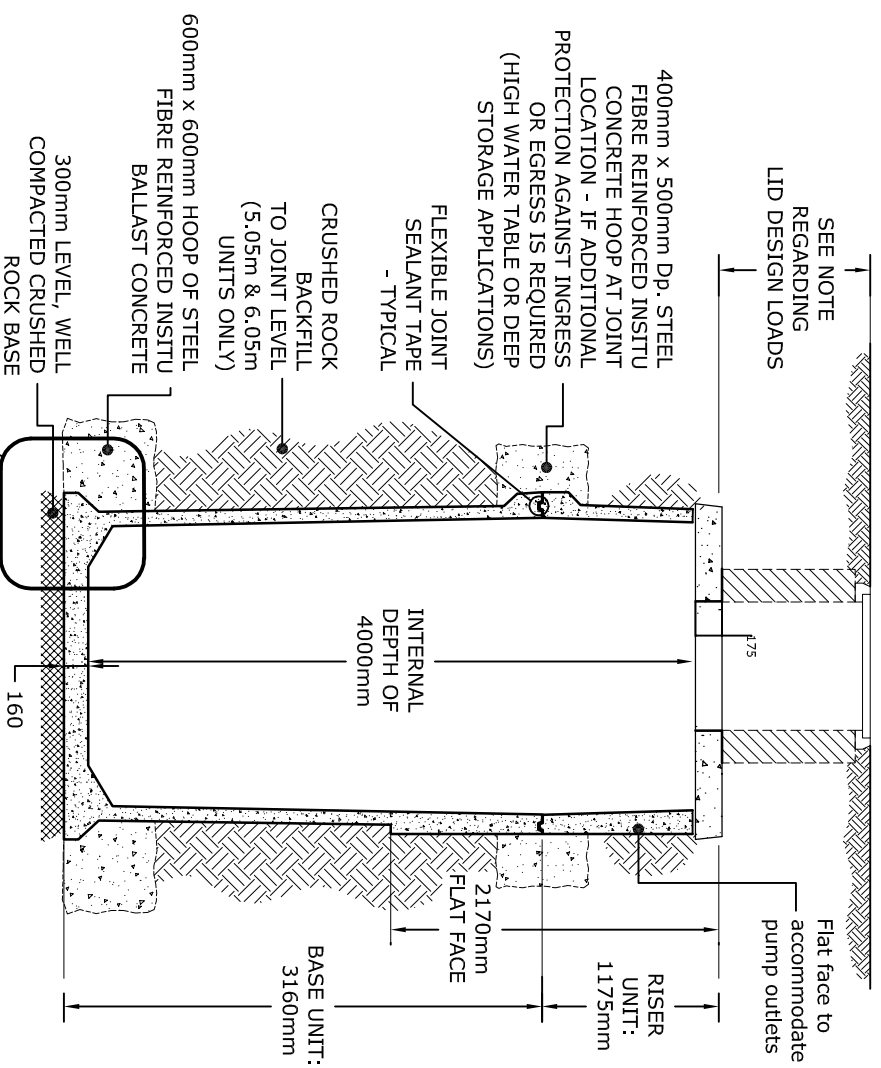

SECTION - TYPICAL PUMP CHAMBER STACK: (BASE UNIT + RISER)
SCALE: 1:50

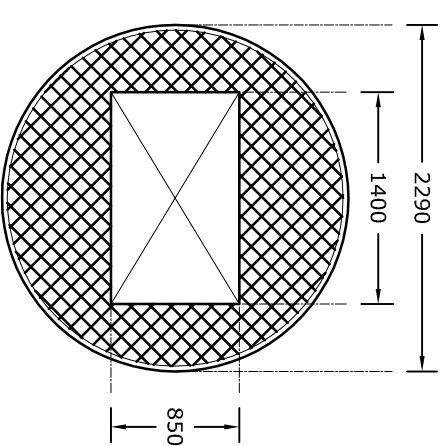

COVER SLAB - PLAN VIEW:
SCALE: 1:50

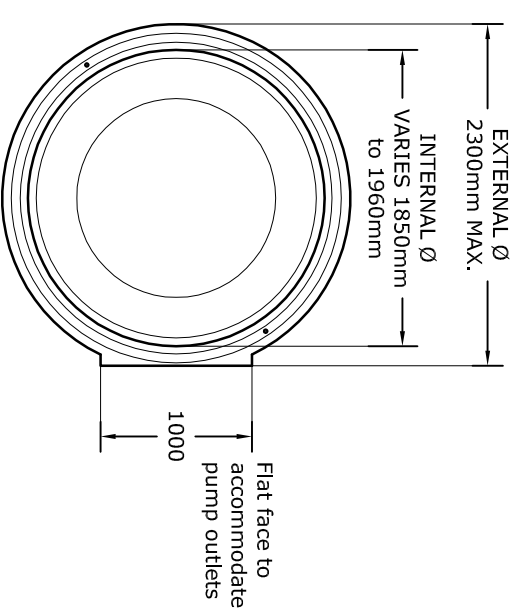

BASE UNIT - PLAN VIEW:
SCALE: 1:50