

DRAWING TITLE:

STANDARD 1.5m Valve Chamber
3.3m³ Total Capacity

1.5m VALVE CHAMBER

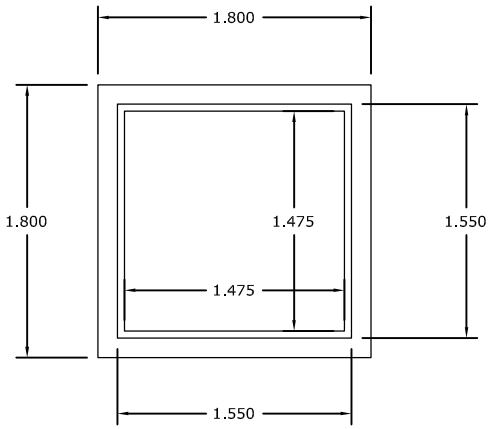

RIM PLAN

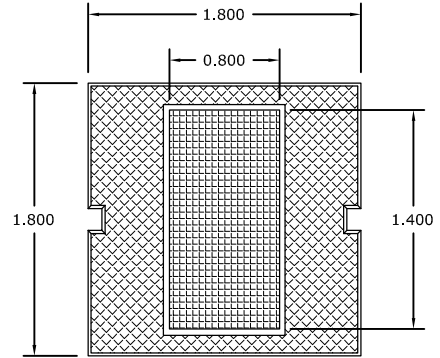

ROOF PLAN

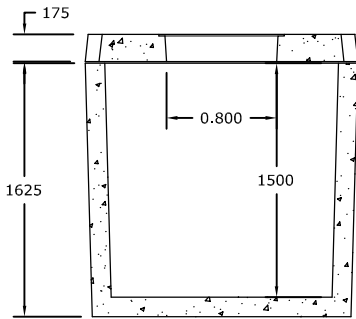

SECTION

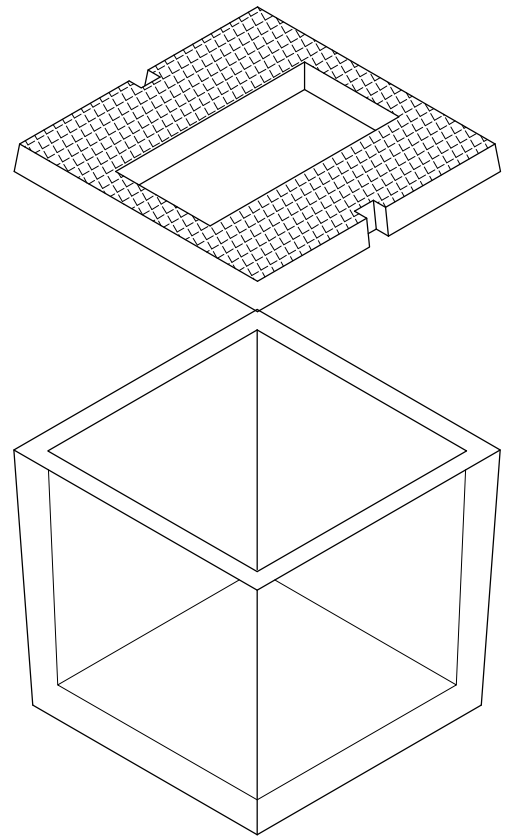

3D VIEW

NOTES:

Weight of chamber without lid 4000kg.

Weight of chamber with lid 4900kg.

Galvanized access cover available on request.

Access opening location to customers requirements.

Grout lifting lug rebates on completion to secure lid in position.

Pipe Openings to customer requirements or formed on site.

0m 1m 2m 3m

